



INSTALLATION AND OWNER GUIDE

Model 347

RADIANT / CONVECTOR GAS FIRE

Fitted with the following fascia

Helmsley



We trust that this guide gives sufficient details to enable this appliance to be installed, operated and maintained satisfactorily. However, if further information is required, our **Valor Fires Technical Helpline** will be pleased to help.

Telephone **0844 879 35 88** (National call rates apply in the United Kingdom).

In the Republic of Ireland Telephone **01 842 8222**.



INSTALLER: Please leave this guide with the owner

THIS APPLIANCE IS FOR USE WITH NATURAL GAS (G20).

**UNDER NO CIRCUMSTANCES IS THIS FIRE TO BE CONVERTED TO LPG.
AN LPG KIT DOES NOT EXIST FOR THIS GAS FIRE.**

**THIS APPLIANCE IS SUITABLE ONLY FOR INSTALLATION IN THE UNITED
KINGDOM (GB) AND THE REPUBLIC OF IRELAND (IE).**

GDC Group Limited

All rights reserved. No part of this publication may be reproduced in any material form (including photocopying), stored in any medium by electronic means (including in any retrieval system or database) or transmitted, in any form or by any means, whether electronic, mechanical, recording or otherwise, without the prior written permission of the copyright owner.

Applications for the copyright owner's permission to reproduce any part of this publication should be made, giving details of the proposed use, to the following address: The Company Secretary, GDC Group Ltd., Millbrook House, Hedge End, Southampton, SO30 2DF.

Warning: Any person who does any unauthorised act in relation to a copyright work may be liable to criminal prosecution and civil claims for damages.



Valor Fires, GDC Group Ltd., Millbrook House, Hedge End, Southampton, SO30 2DF

Because our policy is one of constant development and improvement, details may vary slightly from those given in this publication.

Safety First.

Valor Fires fires are CE Approved and designed to meet the appropriate British Standards and Safety Marks.



Quality and Excellence.

All Valor Fires fires are manufactured to the highest standards of quality and excellence and are manufactured under a BS EN ISO 9001 quality system accepted by the British Standards Institute.



The Highest Standards

Valor Fires is a member of SBGI and HHIC (Heating and Hot water Industry Council) that work to ensure high standards of safety, quality and performance.



This gas fire must be installed by a competent GAS SAFE REGISTER engineer (CORGI or GAS SAFE REGISTER engineer outside of UK) in accordance with our installer guide and should not be fitted directly on to a carpet or floor of combustible material.



INSTALLER GUIDE

FOR OWNER GUIDE SEE PAGES 29 TO 44

INSTALLER GUIDE

CONTENTS

<u>Section</u> <u>Heading</u>	<u>Page</u>
INSTALLER GUIDE	4 - 28
OWNER GUIDE	29 - 43
1. SAFETY AND THE BENCHMARK SCHEME	7
2. LIST OF ACCESSORIES	7
3. APPLIANCE DATA AND EFFICIENCY	8
3.1 Appliance data.	8
3.2 Efficiency.	8
4. GENERAL INSTALLATION REQUIREMENTS	9
4.1 Regulations, Standards and Law.	9
4.2 Ventilation.	10
4.3 The Atmosphere sensing device (ASD).	10
4.4 Room considerations.	10
4.5 Chimney preparation.	11
4.6 Fireplace preparation.	11
4.7 Fireplace clearances.	12
4.8 The Flue spigot.	13
4.9. The hearth.	14
4.10 Installation options.	14
4.10.1 Conventional fireplace.	14
4.10.2 Precast flues.	14
4.10.3 Wall mounting to conventional or pre-cast flues.	15
4.10.4 Metal flue box.	16
4.11 Flues.	16
5. PRE-INSTALLATION PREPARATION	17
5.1 Unpacking.	17
5.2 Appliance preparation.	17
5.3 Fitting the battery to electronic ignition model	18
5.4 Checking the ignition	18
5.4.1 Electronic ignition	18
5.5 Fireplace flue pull.	18
5.6 Fit the closure plate.	19
6. APPLIANCE INSTALLATION	20
6.1 Installing to a hearth.	20
6.2 Wall mounting.	20
6.3 Gas supply connection.	20
6.4 Radiants installation.	20
6.5 Flue restrictor adjustment.	21

Continued on next page

INSTALLER GUIDE

CONTENTS (Continued)

<u>Section Heading</u>	<u>Page</u>
7. CONTROL AND PRESSURE CHECKS	22
7.1 Check control settings.	22
7.2 Flame supervision and spillage monitoring system.	22
7.3 Check reference pressure.	23
8. FASCIA FITTING	23
9. SPILLAGE CHECK	24
10. FINAL REVIEW	25
11. SERVICING AND PARTS REPLACEMENT	26
11.1 To replace radiant(s).	26
11.2 To remove the fascia.	27
11.3 To replace the pilot unit.	27
11.4 To remove the complete burner module, pipes and pilot.	28
11.5 To grease the gas tap.	28

INSTALLER GUIDE

1. SAFETY

Installer

Before continuing any further with the installation of this appliance please read the following guide to manual handling:

- The lifting weight of this appliance is 15.0 kg.
- One person should be sufficient to lift the fire. If for any reason this weight is considered too heavy then obtain assistance.
- When lifting always keep your back straight. Bend your legs and not your back.
- Avoid twisting at the waist. It is better to reposition your feet.
- Avoid upper body / top heavy bending. Do not lean forward or sideways whilst handling the fire.
- Always grip with the palm of the hand. Do not use the tips of fingers for support.
- Always keep the fire as close to the body as possible. This will minimise the cantilever action.
- Use gloves to provide additional grip.
- Always use assistance if required.

This appliance does not contain any component manufactured from asbestos or asbestos related products.

GDC Group is a licensed member of the **Benchmark Scheme** which aims to improve the standards of installation and commissioning of domestic heating and hot water systems in the UK and to encourage regular servicing to optimise safety, efficiency and performance. Benchmark is managed and promoted by the Heating and Hotwater Industry Council. It places responsibilities on both manufacturers and installers. The purpose is to ensure that customers are provided with the correct equipment for their needs, that it is installed, commissioned and serviced in accordance with the manufacturer's instructions by competent persons and that it meets the requirements of the appropriate Building Regulations.

The Benchmark Checklist (on the inside back pages of this guide) can be used to demonstrate compliance with Building Regulations and should be provided to the customer for future reference. Installers are required to carry out installation, commissioning and servicing work in accordance with the Benchmark Code of Practice which is available from the Heating and Hotwater Industry Council who manage and promote the Scheme. Visit www.centralheating.co.uk for more information. At the time of commissioning, complete all relevant sections of the Benchmark Checklist located on the inside back pages of this document.

2. LIST OF ACCESSORIES

Description	Part number
Spigot extension	0595191

INSTALLER GUIDE

3. APPLIANCE DATA AND EFFICIENCY

3.1 Appliance data.

The appliance information label is on the inner face of the back panel at the lower left hand side. It is visible when the fascia is removed.

Gas	Natural (G20)
Inlet Pressure	20mbar
Input - Max. (Gross)	5.5 kW (18,767 Btu/h)
Input - Min. (Gross)	1.57W (5,357 Btu/h)
Burner Test Pressure (Cold)	17.95 ± 0.75mbar (7.2 ± 0.3in w.g.)
Gas Connection	8mm pipe
Burner Injector - Upper (Centre Radiants)	Cat 28 - 170
Burner Injector - Lower (Outer Radiants)	Cat 28 - 170
Pilot & Atmosphere Sensing Device	P4-93
Ignition	Electronic (Mounted on gas valve)
Aeration	Non-adjustable

3.2 Efficiency.

The efficiency of this appliance has been measured as specified in BS 7977 - 1 and the result is as below:

<u>Model</u>	<u>Efficiency % (Gross)</u>
347 Helmsley	73

The gross calorific value of the fuel has been used for this efficiency calculation. The test data from which it has been calculated has been certified by BSI.

The efficiency value may be used in the UK Government's Standard Assessment Procedure (SAP) for energy rating of dwellings.

The conversion of **net** efficiency to **gross** was achieved by multiplying the net efficiency by the following conversion factor from Table E3 of SAP 2005, rounding down to the nearest whole number.

Gas	Conversion factor from net to gross efficiency
Natural Gas	0.901

4. GENERAL INSTALLATION REQUIREMENTS

4.1 Regulations, Standards and Law.

The installation must be in accordance with these instructions.

For the user's protection, in the United Kingdom it is the law that all gas appliances are installed by competent persons in accordance with the current edition of the Gas Safety (Installation and Use) Regulations. Failure to install the appliance correctly could lead to prosecution. GAS SAFE REGISTER and CORGI require their members to work to recognised standards.

In the United Kingdom the installation must also be in accordance with:

- All the relevant parts of local regulations.
- All relevant codes of practice.
- The relevant parts of the current editions of the following British Standards:-
 - BS 715 - Specification for metal flue boxes for gas-fired appliances not exceeding 20kW.
 - BS EN 1806 - Chimneys – Clay/ceramic flue blocks.
 - BS 5440 Part 1 - Flueing and ventilation for gas appliances of rated input not exceeding 70 kW net (1st, 2nd and 3rd family gases).
Specification for installation of gas appliances to chimneys and for maintenance of chimneys.
 - BS 5440 Part 2 - Installation and maintenance of flues and ventilation for gas appliances of rated input not exceeding 70 kW net (1st, 2nd and 3rd family gases).
 - BS 6891 - Installation of low pressure gas pipework of up to 35mm (R1 ¼) in domestic premises (2nd family gas) - specification.
 - BS 1251 - Fireplace components.
 - BS EN 1856 Part 1 - Chimneys – Requirements for metal chimneys.
 - BS 5871 Part 1 - Specification for the installation and maintenance of gas fires, convector heaters, fire/back boilers and decorative fuel effect gas appliances. Gas fires, convector heaters, fire/back boilers and heating stoves (2nd and 3rd family gases).
 - BS EN 1858 - Chimneys – Components – Concrete flue blocks.
 - BS EN 15287 Part 1 - Chimneys. Design, installation and commissioning of chimneys. Chimneys for non-room sealed heating appliances.
- In England and Wales, the current edition of the Building Regulations issued by the Department of the Environment and the Welsh Office.
- In Scotland, the current edition of the Building Standards (Scotland) Regulations issued by the Scottish Executive.
- In Northern Ireland, the current edition of the Building regulations (Northern Ireland) issued by the Department of the Environment for Northern Ireland.
- In the Republic of Ireland the installation must be carried out by a competent person and installed in accordance with:

INSTALLER GUIDE

- a) The current edition of IS 813 “Domestic gas installations”.
- b) All relevant national and local rules in force.
- c) The current building regulations.

Where no specific instructions are given, reference should be made to the relevant British Standard Code of Practice.

4.2 Ventilation.

Normal adventitious ventilation is usually sufficient to satisfy the ventilation requirements of this appliance. In GB reference should be made to BS 5440 Part 2 and in IE reference should be made to the current edition of IS 813 “Domestic gas Installations” which makes clear the conditions that must be met to demonstrate that sufficient ventilation is available.

4.3 The Atmosphere sensing device (ASD).

The appliance is fitted with an A.S.D (Atmosphere sensing device). If the appliance closes down after a period of operation for no apparent reason, the consumer should be informed to stop using the appliance until the installation and appliance have been thoroughly checked. The A.S.D will shut the appliance down if an unacceptable amount of harmful products of combustion accumulate. Under no circumstances should the A.S.D be altered or bypassed in any way. Only genuine manufacturer’s replacement parts should be fitted.

4.4 Room considerations.

4.4.1 The appliance must not be installed in any room, which contains a bath, or shower or where steam is regularly present.

4.4.2 An extractor fan may only be used in the same room as this appliance, or in any area from which ventilation for the appliance is taken, if it does not affect the safe performance of the appliance. Note the spillage test requirements detailed further on in this manual. If the fan is likely to affect the appliance, the appliance must not be installed unless the fan is permanently disconnected.

4.4.3 Note that soft wall coverings (e.g. embossed vinyl, etc.) are easily affected by heat. They may scorch or become discoloured when close to a heating appliance. Please bear this in mind when installing.

4.5 Chimney preparation.

4.5.1 If the appliance is intended to be installed to a chimney that was previously used for solid fuel, the flue must be swept clean prior to installation. All flues should be inspected for soundness and freedom from blockages.

4.5.2 Any chimney dampers or restrictors should be removed. If removal is not possible they must be fixed in the open position.

INSTALLER GUIDE

4.6 Fireplace preparation.

4.6.1 The appliance can be fitted to a purpose made proprietary class “O” 150°C surround.

4.6.2 If the fireplace opening is an underfloor draught type, it must be sealed to stop any draughts.

4.6.3 The front of the fireplace should be flat over an area sufficient to ensure a good seal with the closure plate. The flat surface should extend for a height equal to that of the closure plate plus 20mm and for a width equal to that of the closure plate plus 40mm.

4.6.4 If the fire is to be fitted against a wall with combustible cladding, the cladding must be removed from the area shown in figure 1.

4.6.5 The space between the fireplace front face and the back of the fascia must not be filled in.

4.6.6 If the fireplace opening is greater than the acceptable dimensions given in this guide, do not use the back of a fire surround or marble to reduce the opening. This may cause cracking of the surround back or marble.

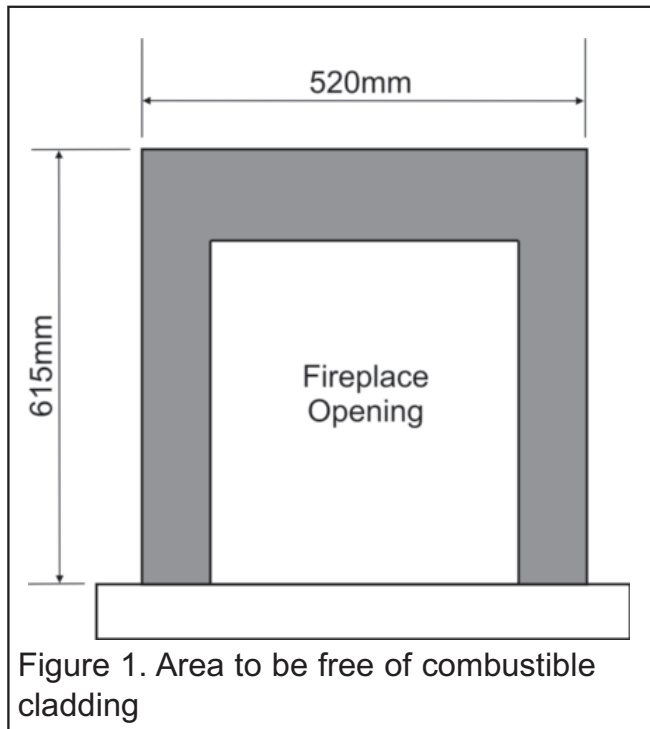
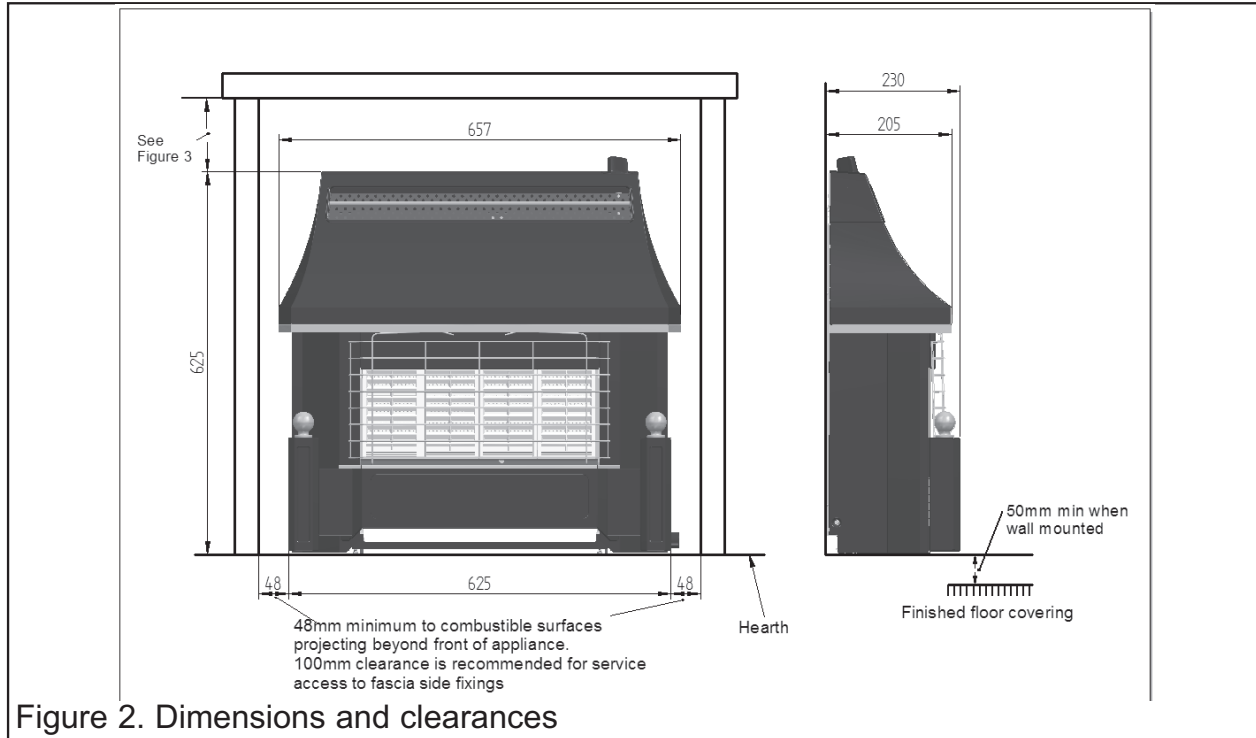

Figure 1. Area to be free of combustible cladding

4.7 Fireplace clearances.

4.7.1 The minimum allowable distance from the outside of the appliance fascia to a corner wall having combustible material or any other combustible surface which projects beyond the front of the appliance is 48mm at either side (See figure 2).



Although no side clearance is necessary to non-combustible surfaces we recommend a 100mm clearance for service access to the fascia side fixings.

4.7.2 Allow a minimum clearance of **95mm** from the top surface of the appliance fascia to the underside of any shelf whether it is made from **combustible or non-combustible** materials. This clearance is necessary to allow the fascia to be lifted off for servicing and also allows the owner sufficient access to operate the control knob. For a shelf made from **wood or other combustible materials deeper than 150mm**, the minimum clearance must be as below.

- For a shelf up to 150mm deep: Minimum clearance = 95mm.
- For a shelf deeper than 150mm: 95mm + 12.5mm for every 25mm depth over 150mm (See Figure 3).

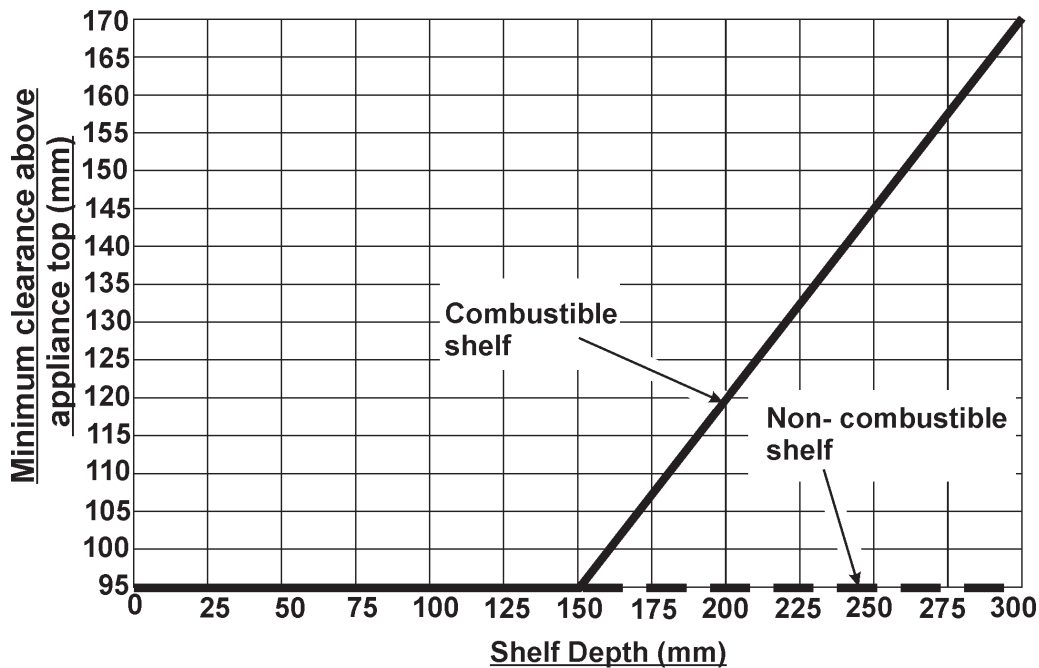

Figure 3. Shelf clearances

4.8 The Flue spigot.

4.8.1 The flue spigot and any spigot extension must be capable of passing through the closure plate by at least 38mm with a minimum clearance of 50mm between its open end and the nearest obstruction.

There must also be a minimum clearance of 165mm between the back of the closure plate and the back of the catchment space.

On conventional flues the catchment space below the flue spigot must extend at least 250mm downwards measured from the bottom of the flue spigot (See figure 4).

4.8.2 A spigot extension is available (Valor Fires part number 0595191). When fitted this shall extend through the closure plate for at least 38mm and have a minimum clearance of 50mm from the end to any surface.

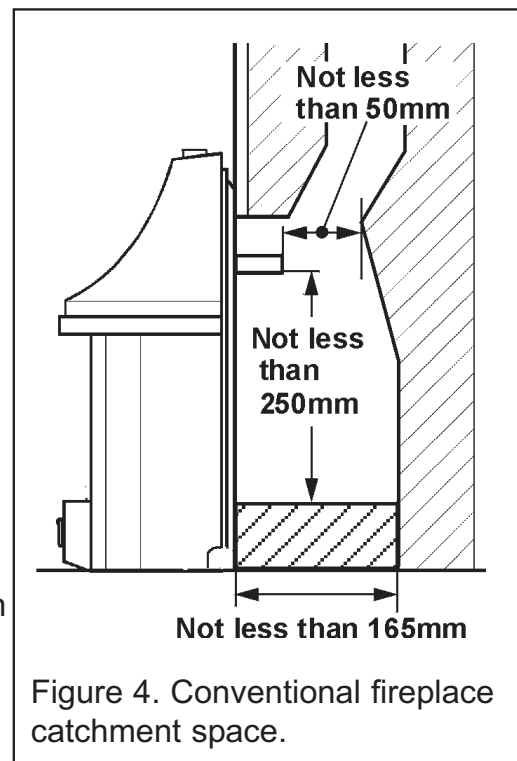

Figure 4. Conventional fireplace catchment space.

INSTALLER GUIDE

4.9. The hearth.

The appliance must be mounted on a non-combustible hearth **except when the conditions in section 4.10.3 are met** (N.B. conglomerate marble hearths are considered as non-combustible). The hearth must be at least 680mm wide x 300mm deep. The hearth material must be at least 12mm thick. The periphery of the hearth (or fender) should be at least 50mm above floor level to discourage the placing of carpets or rugs over it.

4.10 Installation options.

In the United Kingdom, as supplied, this appliance can be installed in the following situations:

4.10.1 Conventional fireplace.

The fireplace opening must be within the following dimensions:

Conventional Fireplace			
Width		Height	
Max.	440mm	Max.	610mm*
Min.	305mm	Min.	525mm

* The total height of the closure plate is 660mm and will accommodate a maximum opening height of 650mm (This allows a 10mm overhang). Heights above 620mm (Inclusive of sealing tape) will leave the sealing tape and closure plate visible above the appliance.

4.10.2 Precast flues.

The appliance can be installed to a fireplace that has a properly constructed precast concrete or clay flue block system conforming to BS EN 1858 or BS1289. The appliance is suitable for installations conforming to older versions of BS1289 as well as the current standards. The flue blocks must have a minimum width not less than 63mm and a cross-sectional area not less than 13,000mm². Older editions of BS1289 required a cross-sectional area of 13,000mm². The current revision of the standard requires 16,500mm². This appliance is suitable in both cases.

The chimney should be one or two storeys high but not less than 3m vertical height and be correctly terminated. No mortar fangs between the blocks should be extruded into the flue way. If raking blocks are used, they must be fitted in accordance with the manufacturer's instructions. Mortar must not be allowed to drop down and accumulate in the raked positions.

INSTALLER GUIDE

The fireplace opening must be within the following dimensions:

Precast flue			
Width		Height	
Max.	440mm	Max.	610mm ^(a)
Min.	305mm	Min.	525mm ^(b)

(a) The total height of the closure plate is 660mm and will accommodate a maximum opening height of 650mm (This allows a 10mm overhang). Heights above 620mm (Inclusive of sealing tape) will leave the sealing tape and closure plate visible above the appliance.

(b) Any opening visible below the appliance may be closed in.

4.10.3 Wall mounting to conventional or pre-cast flues.

The wall opening must be within the following dimensions: The minimum height figures shown reflect that an extra 50mm is required above the **finished floor level** when wall mounting (See figure 2).

Wall mounting			
Width		Height	
Max.	440mm	Max.	610mm [*]
Min.	305mm	Min.	575mm

* The total height of the closure plate is 660mm and will accommodate a maximum opening height of 650mm (This allows a 10mm overhang). Heights above 620mm (Inclusive of sealing tape) will leave the sealing tape and closure plate visible above the appliance.

Wall mounting to a conventional fireplace.

Any opening visible below the appliance may be closed in but the depth of the catchment space within the wall opening must be as shown in figure 4.

Wall mounting to a pre cast flue.

Important: If the base of the opening is above the finished floor level, the base must be a maximum 350mm from the finished floor level. This will ensure that the air relief hole in the closure plate is not covered or reduced.

INSTALLER GUIDE

4.10.4 Metal flue box.

The appliance can be installed to a metal flue box conforming to BS 715 Section 6 (For gas fires to BS 7977-1) having a minimum internal depth of 165mm.

The opening must be within the following dimensions:

Metal Flue Box.			
Width		Height	
Max.	440mm	Max.	610mm*
Min.	380mm	Min.	525mm

* The total height of the closure plate is 660mm and will accommodate a maximum opening height of 650mm (This allows a 10mm overhang). Heights above 620mm (Inclusive of sealing tape) will leave the sealing tape and closure plate visible above the appliance.

In addition the fire has been tested for use with a 'Rite Vent' or 'Selkirk' Flue Gas Collector Box. The opening dimensions may differ from those shown above. It is **IMPORTANT** that each installation passes a properly conducted Spillage test as in section 9.

4.11 Flues.

The following flues are suitable:

- 225mm x 225mm conventional brick flue.
If a flue liner is used, it must be a minimum of 125mm diameter. The liner must be sealed to the surrounding area above the fireplace opening and to the top of the chimney. An approved terminal must be fitted.
- A properly constructed precast flue conforming to BS EN 1806, BS EN 1858 or B.S 1289.
- A flue pipe with a minimum diameter of 127mm. See BS EN 15287-1 for suitable materials. Metal flue pipes must comply with BS EN 1856 part 1. See section 4.10.4 of this guide for flue box opening sizes.
- The flue must conform to BS 5440: Part 1 in design and installation.
The flue, measured from the bottom of the fireplace opening to the bottom of the terminal, shall be not less than 3m in actual vertical height. When calculated in accordance with BS 5440: Part 1 Annex B, the minimum **equivalent** height of the flue shall be 2.0m of 125mm dia. flue pipe.
- The flue must be clear of any obstruction and its base must be clear of debris.
- The flue must be completely sealed so that combustion products do not come into contact with combustible materials outside the chimney.
- The flue must serve only one fireplace.
- Proprietary terminals must comply with BS EN 1858, BS EN 1806 or BS 1289 and older versions of BS 715. Any terminal or termination must be positioned in

INSTALLER GUIDE

accordance with BS 5440 Part 1 to ensure that the products of combustion can be safely dispersed into the outside atmosphere. Where the appliance is connected to an unlined brick chimney it is generally unnecessary for the chimney pot to be replaced or for a terminal to be fitted unless the flue has a diameter smaller than 170mm.

5. PRE-INSTALLATION PREPARATION

5.1 Unpacking.

This appliance is supplied completely assembled except for:-

- 4 radiants which are in a cardboard pack inside the firebox.
- The closure plate.
- Literature pack.
- An olive & olive nut for gas line connection.

Remove all the items carefully to prevent damage. Some items may be contained in the packaging fitments - Examine the packaging carefully before discarding. Check that all the items are present and undamaged.

5.2 Appliance preparation.

1. Stand the fire upright.
2. Remove the two transit screws from near the top of the back panel wings (See figure 5).
3. Remove the control knob by pulling clear of the gas tap spindle.
4. Remove the two fascia retaining screws located at the front of the fascia near the bottom corners.
5. Lift the fascia up and forward to clear the rear top location. Store in a safe place.
6. Remove the radiant pack by gently lifting and pulling forward from the bottom.
7. Remove the cardboard strip from the top of the burner area.
8. Remove any protective film from all the bright trims.
9. If the fire is fitted to a recessed fireplace, an extension flue spigot up to a maximum total length of 125mm may be used. The extension must be a tight fit over the flue spigot and be secured by two self tapping screws. Note the minimum clearance required as shown in figure 4.

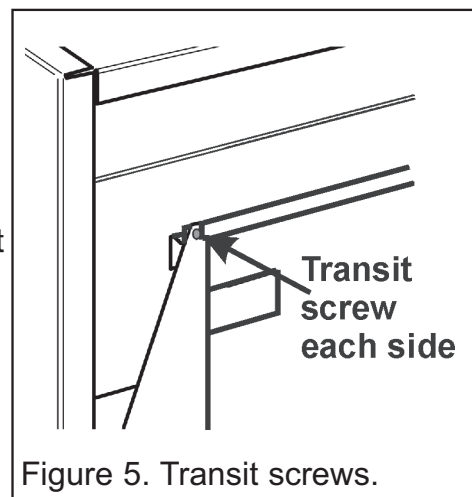

Figure 5. Transit screws.

INSTALLER GUIDE

5.3 Fitting the battery to electronic ignition model.

1. At the front of the electronic spark generator there is a removable circular battery cover. Unscrew the cover in an anticlockwise direction.
2. Remove any protective film from the battery and place into the generator. The negative (-) terminal should go in first. The battery cover is marked with (+).
3. Screw on the cap.

5.4 Checking the ignition.

5.4.1 Electronic ignition.

Before attempting to install, it is worth checking that the electronic spark ignition system operates satisfactorily. To initiate the spark, temporarily fit the control knob to the spindle. Apply pressure to the top of the control knob spindle. Sparks should be generated between the electrode and thermocouple tip on the pilot unit. If there are no sparks or incorrect tracking, check the spark gap between the electrode wire and thermocouple tip (See figure 6).

If the spark gap is correct, check the ignition wiring.

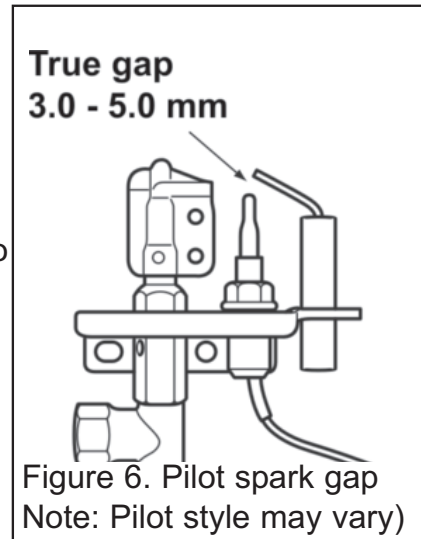

5.5 Fireplace flue pull.

Close all doors and windows in the room in which the appliance is to be installed. After confirming with a match that smoke is drawn into the flue, light a 13 gram smoke pellet and check that there is a definite flow through the flue.

Verify outside that the smoke exits from one terminal only and that the termination is suitable.

Observe, where possible, upstairs rooms and loft spaces for signs of escaping smoke indicating a defective flue. If there is not a definite flow warm the flue for a few minutes and repeat the smoke pellet test. If there is still no definite flow the flue may need remedial work – **Do not fit the appliance until there is a definite flow through the flue.**

5.6 Fit the closure plate.

The spigot opening in the closure plate has two 'flange' sections.

Flange 1 is to be left as supplied.

© GDC Group Limited OCT 2016

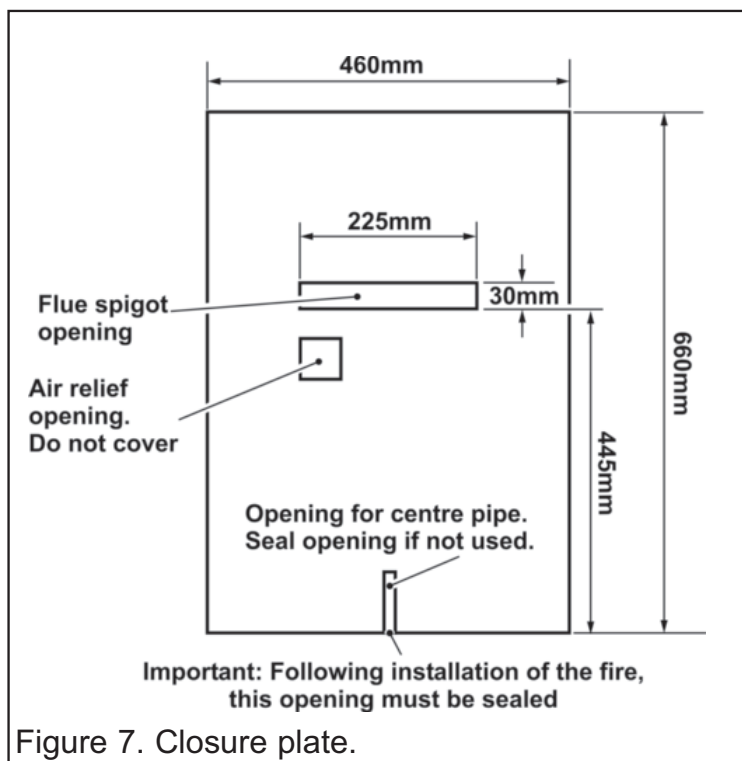

Figure 7. Closure plate.

INSTALLER GUIDE

Fold **Flange 2** along the perforated line. The closure plate has an opening at the bottom for a central gas feed pipe. The gap between the pipe and this opening should be sealed with tape after connection. If a central feed pipe is not required the opening should be completely sealed with tape.

The closure plate dimensions will now be as shown in figure 7.

5.6.1 Hearth mounting. (See figure 8).

The closure plate must be fitted and sealed to the hearth and fireplace opening using a suitable heat resistant material. If necessary cut the closure plate but make sure that it overlaps the fireplace opening sufficiently to allow satisfactory sealing. Make sure that the square air relief opening is fully within the fireplace opening.

5.6.2 Wall mounting. (See fig 9).

The closure plate must be fitted and sealed to the hearth and fireplace opening using a suitable heat resistant material. If necessary cut the closure plate but make sure that it overlaps the fireplace opening sufficiently to allow satisfactory sealing. Make sure that the square air relief opening is fully within the fireplace opening.

The bottom of the appliance must be at least 50mm above any carpet or other floor covering. To achieve this, the bottom of the flue spigot opening must be at least the minimum dimension shown in fig 9.

5.6.3 Check the flue pull with closure plate fitted by applying a lighted match or smoke match to the flue spigot opening in the closure plate and observe the smoke. If there is a definite flow continue with the installation. If not check the fitting of the closure plate. The fireplace flue pull check described in section 5.3 should have confirmed that the fireplace itself is satisfactory.

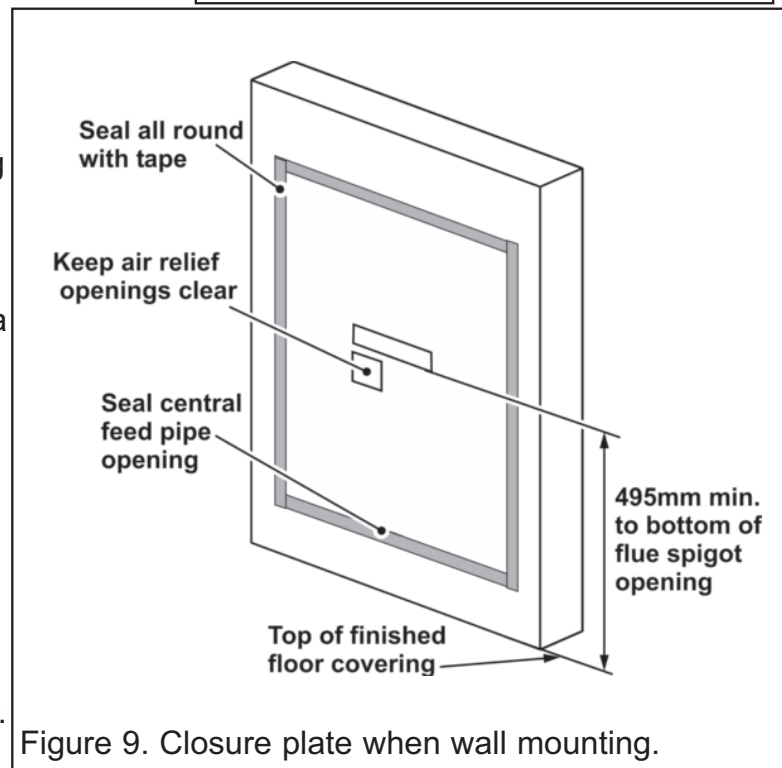
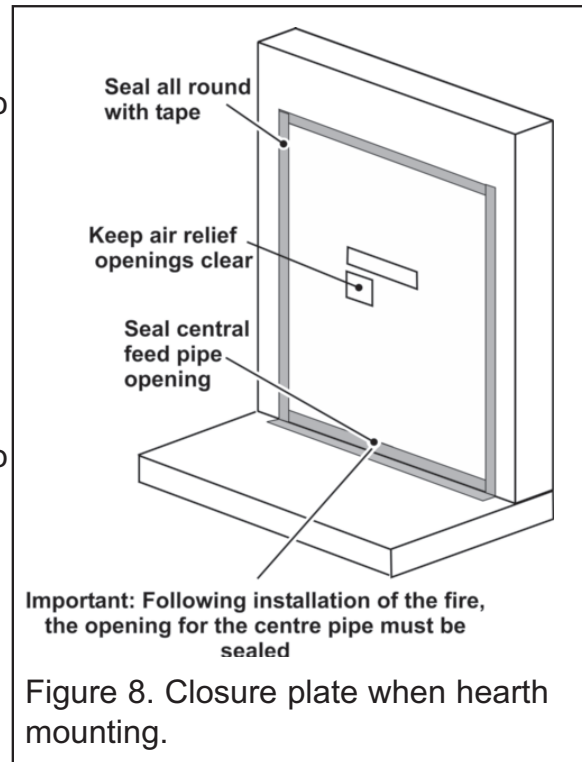

INSTALLER GUIDE

6. APPLIANCE INSTALLATION

6.1 Installing to a hearth.

1. Place the fire centrally on the hearth making sure that the spigot lines up with the spigot hole in the closure plate. Gently slide the appliance into place **being careful not to scratch the hearth**. The spigot must enter the closure plate to a depth of at least 38mm.

2. Level the fire by loosening the lock nuts and turning the levelling screws in the feet up or down as required while they bear on the hearth. When the fire is level and square to the wall, retighten the lock nuts.

6.2 Wall mounting.

The fixing hole positions in relation to the flue spigot opening are shown in figure 10. Mark these positions on the wall. The positions can alternatively be marked by placing the fire in position and marking the wall through the holes in the back panel.

Drill and plug the holes using no.10 wall plugs. Place the fire in position and secure with four no.10 x 2in. wood screws.

6.3 Gas supply connection.

8mm rigid tubing must be used to connect the gas supply to the appliance. An olive and nut are provided for connection to the inlet "T" connector on the appliance. The connector can be rotated to allow connection from either side or the rear. The connector includes a valve for isolating the gas supply.

The closure plate has a cut-out for rear connection. Seal the gap between the cut-out and the supply pipe.

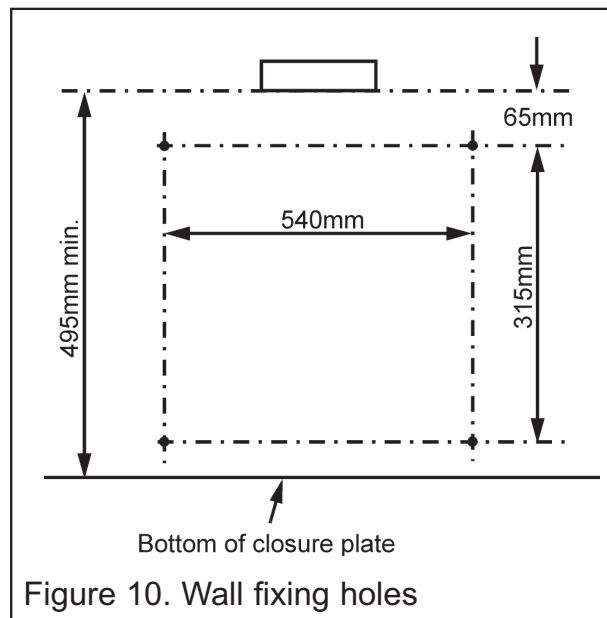

Figure 10. Wall fixing holes

Pressure check the installation pipework for gas soundness. In the United Kingdom check in accordance with the current edition of BS6891. In the Republic of Ireland refer to the current edition of IS 813 "Domestic gas installations".

6.4 Radiants installation.

Important: Fit the radiants ensuring that their rear face rests against the horizontal ribs in the rear panel. There will be a small gap between their bottom front edges and the retaining channel at the front of the radiant box.

6.5 Flue restrictor adjustment.

(See figure 11).

The appliance has an integral adjustable flue draught restrictor. This is supplied set in the fully open (unrestricted) position and in most cases no adjustment should be necessary. It can be reset to a fully restricted position if the flue draught is excessive. The restrictor must remain in its fully open position if the flue has an equivalent height of 4m or less (as calculated in accordance with BS5440: Part 1 Appendix B).

INSTALLER GUIDE

Generally we recommend the restrictor is NOT fitted where a precast flue is used, however, certain flues may work sufficiently to warrant its use. There may however, be circumstances where fitting the restrictor causes the fire to fail the spillage test. In such cases the restrictor will have to be re-opened. After opening conduct the spillage check again.

To close the restrictor:

1. Loosen the screw situated behind the cut-out in the black upper heat shield. Do not fully remove the screw (See figure 11).
2. Push the restrictor firmly down as far as it will go. The top of the slot in the restrictor bracket should touch the screw.
3. Fully tighten the screw.

If closing the restrictor causes the fire to fail the spillage test it will have to be reopened.

To open the restrictor:

1. Loosen the screw situated behind the cut-out in the black upper heat shield. Do not fully remove the screw.
2. Push the restrictor firmly up as far as it will go. The bottom of the slot in the restrictor bracket should touch the screw.
3. Fully tighten the screw.

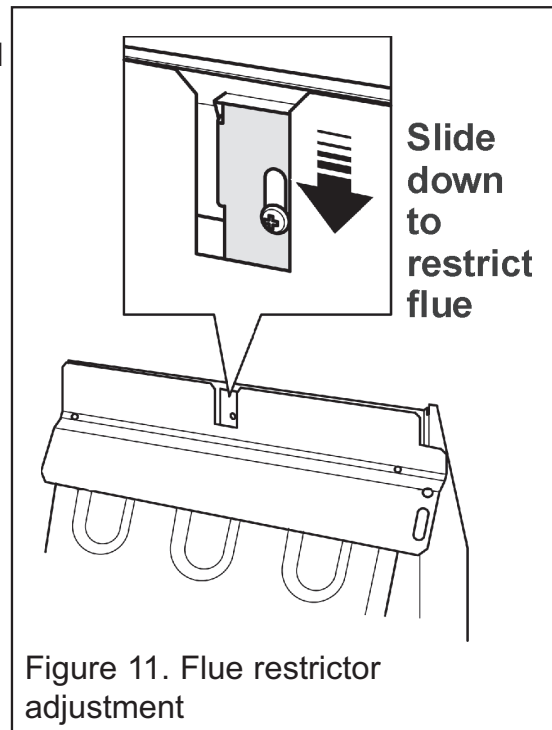

Figure 11. Flue restrictor adjustment

INSTALLER GUIDE

7. CONTROL AND PRESSURE CHECKS

7.1 Check control settings.

1. If closed, open the isolating valve at the inlet 'T' connector.
2. To check the control positions temporarily place the fascia loosely over the engine. Fit the control knob over the gas tap spindle.
3. Depress the control knob and **slowly** turn anticlockwise partially towards the 1/IGN position until some resistance is felt. Keep depressed at this position for a few seconds to purge air from the system then, while keeping it depressed, turn fully to the 1/IGN position. A spark should be generated at the pilot while turning. The spark should ignite the pilot. If it does not, keeping the knob depressed, continue to **slowly** turn the knob anticlockwise. A **second spark** should be generated at the pilot while turning. This spark should ignite the pilot.
4. When pilot ignition has been achieved, keep the control knob depressed for approximately ten seconds to allow the thermocouple probe to warm up and then release it. If the pilot does not remain alight, ensure that the air has been purged, that the pilot orifice is clear and that the thermocouple connections are sound. Replace the pilot unit if necessary (See servicing section of this guide).
5. Check all the control settings. These are: -

Control Knob Position	Radiants Condition
2	Centre radiants on low. Outer radiants off.
3	Centre radiants fully on. Outer radiants off.
4	Centre radiants fully on. Outer radiants on low.
5	All radiants fully on.

7.2 Flame supervision and spillage monitoring system.

The pilot unit incorporates a system that will automatically shut off the gas supply if the pilot flame goes out or if there is insufficient oxygen due to spillage or lack of ventilation.

Check that the system operates properly as follows:

1. Light the appliance. Set at position 5 and leave for one minute.
2. Turn back to "OFF" to extinguish the pilot. **Note the time when the pilot goes out.** Listen for a snap sound at the gas tap. **Note the time when the sound is heard.** An electromagnetic valve shutting off the gas supply through the tap causes this sound. The valve is located in the body of the tap. The valve should operate **within 60 seconds of the pilot going out.** If the valve does not operate within this time limit do not allow the appliance to be used until the fault has been corrected.

This monitoring system must not be adjusted, bypassed or put out of operation.

This monitoring system, or any of its parts, must only be exchanged using Valor Fires authorised parts.

INSTALLER GUIDE

7.3 Check reference pressure.

The appliance is pre-set to give the correct heat input at the inlet pressure shown in section 3 of this manual. No adjustment is necessary.

1. Ensure that the fire is turned OFF and detach the control knob from the spindle. Remove the fascia. Remove the fascia and replace the control knob.
2. Check the burner pressure by fitting a pressure gauge at the test point. The test point is on the gas tap. Check the pressure with the appliance alight and set at maximum output (Control position 5).
3. After checking, turn off the appliance. Remove the pressure gauge and replace the test point sealing screw. Relight the appliance. Turn to the maximum output position and test around the sealing screw for gas soundness with a suitable leak detection fluid. Turn the fire OFF and detach the control knob from the spindle.
4. If all the above checks are satisfactory, continue with the installation. If not, check the control and ignition circuitry and components as described in the servicing section of this manual.

8. FASCIA FITTING

Before continuing with the installation of this appliance it is important that the information contained on the back pages of the Owner guide is completed.

- Place the fascia over the engine. Make sure that the channel near the top of the rear of the fascia locates fully into the wings of the engine back panel (See figure 12).

The fire is fitted with a 'Top Hat' style control knob that all users including elderly or infirm should find easier to grip and use.

- Fit the control knob firmly on to the control spindle.

- Refit the two fascia retaining screws at the rear of the fascia near the bottom.

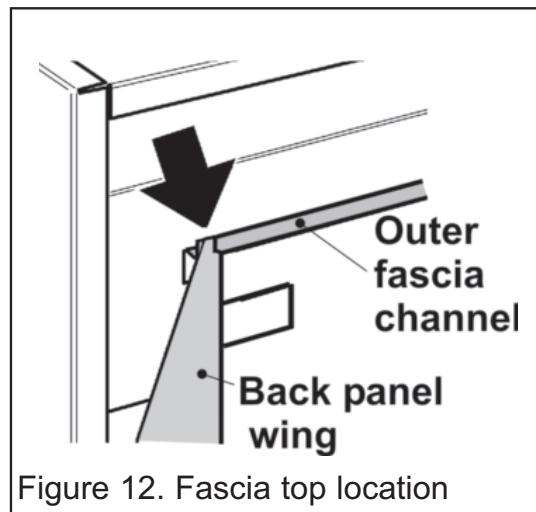

Figure 12. Fascia top location

INSTALLER GUIDE

9. SPILLAGE CHECK

A spillage check must be made before leaving the installed appliance with the customer. Make this with all radiants and complete fascia in position.

1. Close all doors and windows in the room containing the fire.
2. Light the appliance and set the control knob to the maximum position (Position 5).
3. Leave the appliance on for five minutes.
4. Place a smoke match tube (with lighted match) horizontally underneath the radiant box but touching the top lip of the box.

The tube should be between the two centre radiants. The tip of the match should project between 2mm and 5mm beyond the lowest edge of the radiant box lip (See figure 13).

5. The installation is satisfactory if the smoke is drawn into the appliance. If the smoke is not drawn into the appliance, leave the appliance alight at the maximum setting for a further ten minutes and then repeat the test. If the smoke is still not drawn into the appliance, inspect the sealing of the closure plate. If the sealing is satisfactory but the appliance is installed with the flue restrictor in the closed position (See section 6.5),

reopen the restrictor, reseal the appliance and retest. **If smoke is still not drawn into the appliance, disconnect the appliance and seek expert advice**

6. If the above test is satisfactory, open all internal connecting doors, hatches, etc. in the room. Keep all doors and windows that open to the outside of the building closed. Recheck for spillage as above. If an extractor fan is installed in the same room as the appliance or a connecting room, check that spillage does not occur with the fan operating and all doors and other openings between the fan and the appliance open. If the test is satisfactory continue with the installation. **If the test is not satisfactory disconnect the appliance and advise the customer of the cause of failure.**

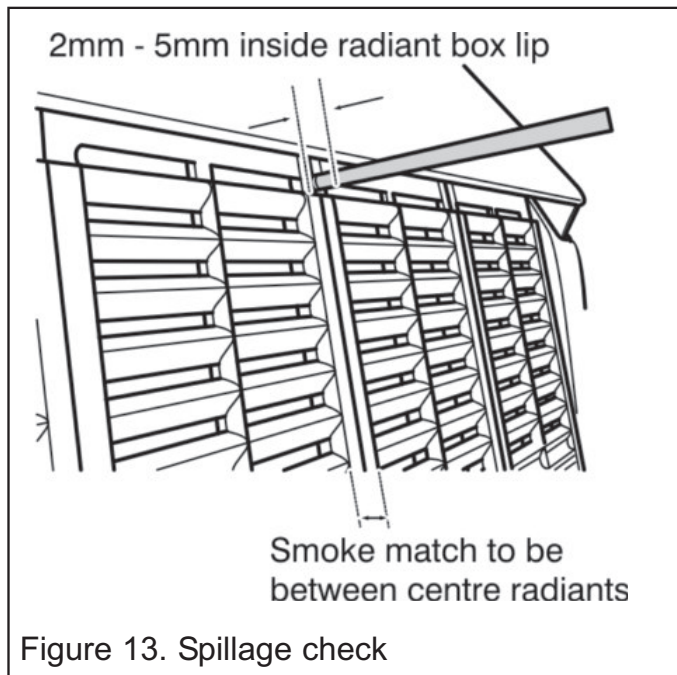

INSTALLER GUIDE

10. FINAL REVIEW

- **COMPLETE THE INFORMATION IN THE WARRANTY AND SERVICE SECTION OF THE OWNER GUIDE (See last pages of the OWNER guide).**
- Make sure that the dress guard is securely in position.
- Recheck the operation of the fire at all control positions. **Explain to the customer that the appliance is fitted with a two-spark ignition system (See section 7.2 point 3).**
- Visually inspect the appliance. Clean off any marks incurred during installation.
- Advise the customer how to operate the fire.
- Explain to the customer that the appliance has a flame failure and spillage monitoring system. Point out the explanation of this system shown in the owner guide. Advise that if the fire goes out for any reason, wait at least three minutes before relighting. Stress that if the monitoring system repeatedly shuts off the fire, the appliance should be switched off and a specialist should be consulted.
- Advise that the dressguard can be removed to replace the radiants.
- Advise that the fire may give off a slight odour while new. This is quite normal and it will disappear after a short period of use.
- Advise that any cleaning must only be carried out when the fire is off and cold.
- Advise the customer that they should read the owner guide before operating the fire and always follow the advice in the section headed “Cleaning your fire”.
- Advise the customer that the appliance can be lit with a match if necessary by inserting it through the opening at the bottom of the fascia (See the ‘Operating your fire’ section in the owner guide).
- Recommend that the appliance should be serviced and the chimney inspected by a competent person (In the UK a GAS SAFE REGISTER engineer, CORGI or GAS SAFE REGISTER outside of UK) at least annually.
If the appliance is in premises in the United Kingdom occupied by a tenant, point out that by law a landlord must have any gas appliance, flue and pipework which is situated in a tenant’s premises checked for safety at least every 12 months.
- Mention that the radiants may become brown with use, that this is quite normal and has no adverse effect.
- **Inform the user that the serial number for the fire is on a label at the bottom of the fascia, usually on the right side.**
- Hand this guide to the customer.

INSTALLER GUIDE

11. SERVICING AND PARTS REPLACEMENT

- Always turn off the gas supply and allow the appliance to cool completely before commencing any servicing (The appliance inlet “T” connector incorporates an isolating valve).
- It is recommended that, at least once a year, the appliance is disconnected and the catchment space behind the closure plate checked and cleared of any debris. The closure plate must be resealed to the wall after checking.
- Check that soot or debris is not impairing the electrode spark or pilot burner.
- Check that soot or debris is not blocking any of the holes in the main burner.
- **Always test for gas soundness and spillage after servicing the appliance.**

11.1 To replace radiant(s).

Always use the correct type of replacement radiant. Ask for Valor Fires part number 5132071 (Single Radiant).

- Remove the dress guard by pressing down the two hooks at the top. Tilt the guard forward and lift out (See figure 14).

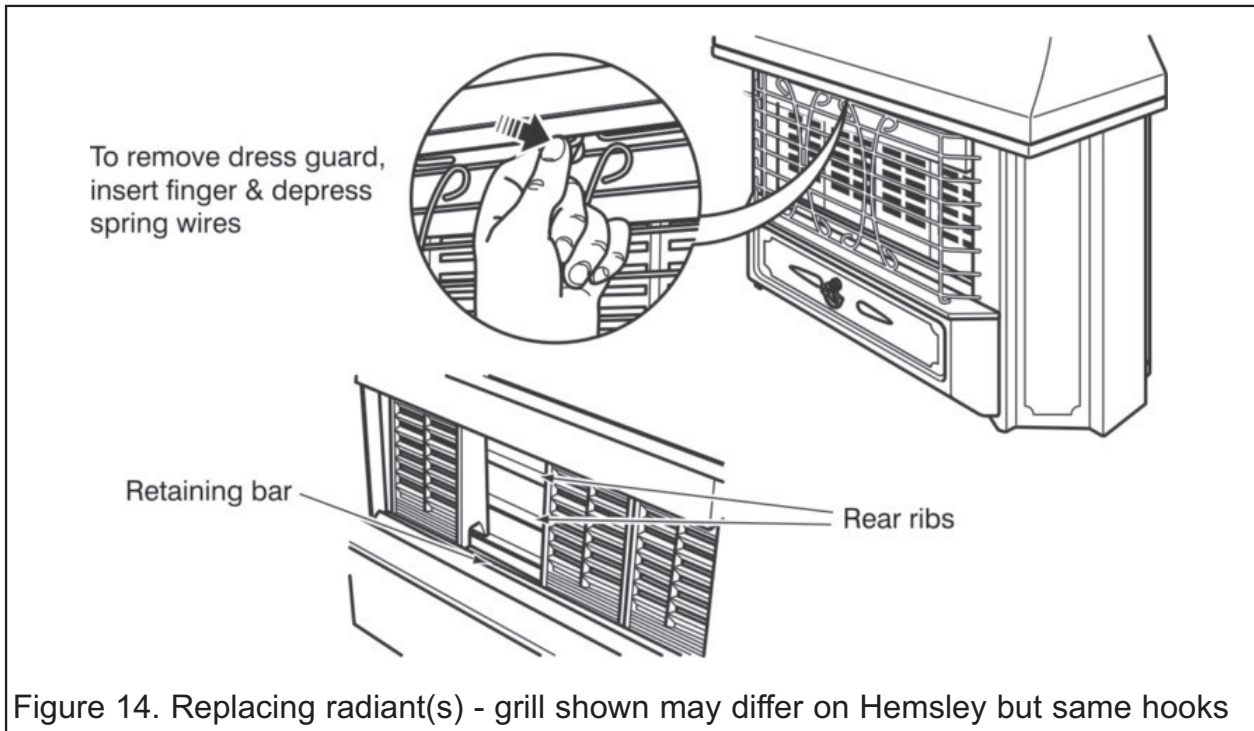

- Lift the radiant upward to clear the metal retaining bar then pull out bottom first.
- Fit the new radiant by inserting its top under the top lip of the radiant box then swing the bottom of the radiant over and behind the retaining bar. **It is important that that the rear face of the radiants rest against the horizontal ribs in the rear panel. There will be a small gap between their bottom front edges and the retaining channel at the front of the radiant box.**

INSTALLER GUIDE

– Replace the dress guard. Locate the bottom of the dress guard in the two holes in the bottom panel apron. Push the guard back so that the two spring projections at the top of the guard engage in the slots under the front decorative canopy.

11.2 To remove the fascia.

1. Remove the control knob by pulling clear of the gas tap spindle.
2. Remove the two fascia retaining screws located at the rear of the fascia near the bottom.
3. Lift the fascia up and forward to clear the rear top location.
4. Replace in the reverse order. Make sure that the channel near the top of the rear of the fascia locates fully into the wings of the engine back panel (See figure 12) in the installation section.

Make sure that the radiants are not dislodged when refitting the fascia.

11.3 To replace the pilot unit.

1. Remove the fascia as section 11.2 above.
2. Disconnect the thermocouple connection at the bottom of the gas tap.
3. Disconnect the pilot pipe from the gas tap. It is the upper connection at the right side of the tap.
4. Remove the first screw securing the dust cage to the pilot unit & burner bracket. Carefully remove the dust cage and place aside. Remove the second screw securing the pilot unit to the burner bracket.
5. Disconnect the electrode lead from below the pilot electrode.
6. Carefully remove the pilot unit together with the pilot pipe then disconnect the pipe from the pilot unit.
7. Replace in the reverse order.

Note: 1 The pilot unit must be replaced as a whole assembly. Its individual components are not separately replaceable.

2. *Once removed, ensure that the dust cage is cleaned before refitting. Make sure that it locates squarely onto the pilot unit without any gaps between the cage edges and the pilot unit.*

INSTALLER GUIDE

11.4 To remove the complete burner module, pipes and pilot.

1. Remove the fascia as section 11.2.
2. Support the inlet 'T' connector to avoid straining the pipework and disconnect the appliance.
3. Disconnect the control spindle and adapter from the gas tap by removing the split pin. Lift the adapter clear of the gas tap spindle.
4. Detach the left end of the burner module from the radiant box by removing one screw and a wing nut (See figure 15).
5. Carefully slide the burner module to the right to free it from the right side of the radiant box (See figure 15).
6. Remove the pipes, gas tap or injectors as required.
7. Replace in the reverse order.
Take care when replacing the injectors. The injectors have ceramic tips at each end. It is important not to allow jointing compound to get on either end of the injectors.
Make sure that the control knob with spindle is correctly turned to agree with the gas tap position before refitting the split pin.

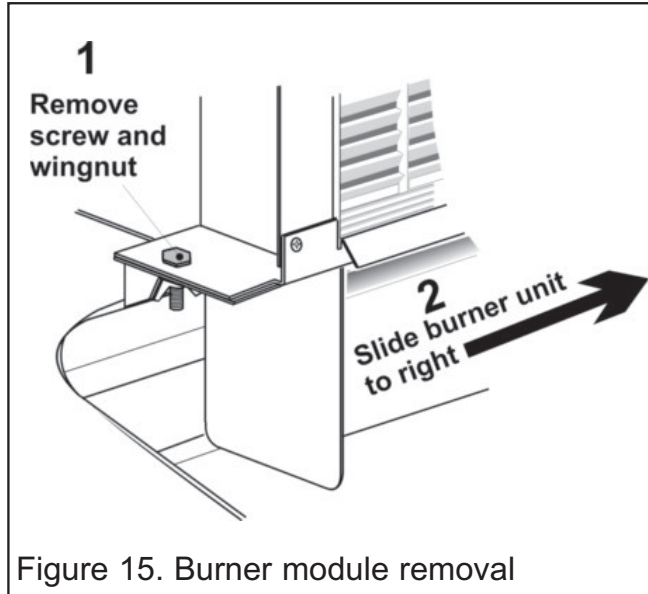

Figure 15. Burner module removal

11.5 To grease the gas tap.

1. Remove the burner module as section 11.4.
2. Remove the circlip holding the piezo generator to the tap.
3. Remove the two screws from the head of the tap.
4. Remove the spindle and spring from the tap.
5. Note the position of the slot in the plug. Mark this position on the tap body.
6. Rotate the plug and pull it out of the tap.
7. Clean and grease the plug lightly with suitable grease. Do not apply excessive grease. Particularly, make sure that the gas ports are not restricted by grease.
8. Push the plug back into the tap body. Line up the slot in the plug with the mark previously made on the tap body.
9. Reassemble in the reverse order making sure that the components are correctly engaged. Check the operation of the tap and piezo. Make sure that the control knob with spindle is correctly turned to agree with the gas tap position before refitting the split pin.

OWNER GUIDE

FOR WARRANTY, SERVICE AND BENCHMARK
SERVICE INFORMATION SEE PAGES 37 TO 44

OWNER GUIDE

LIST OF CONTENTS

<u>Section</u>	<u>Page</u>
SAFETY	31
GAS CONSUMPTION	32
APPLIANCE DIMENSIONS	33
OPERATING YOUR FIRE	33
The Oxysafe flame sensing and flue blockage safety system.	33
To light the fire.	34
CLEANING YOUR FIRE	35
REPLACING THE RADIANTS	35
MAINTENANCE	36
Regular maintenance.	36
WARRANTY, SERVICE AND BENCHMARK	38 - 40
BENCHMARK COMMISSIONING CHECKLIST	39
BENCHMARK SERVICE RECORD	40
SERIAL NUMBER LABEL	41 - 42

This gas fire is designed to meet the most stringent quality, performance and safety requirements to provide you with many years' trouble-free service.

This guide aims to improve your understanding and appreciation of your gas fire by providing simple and informative instructions to ensure that you benefit from the excellent performance and features it has to offer.

OWNER GUIDE

SAFETY

IF YOU SMELL GAS

- **DON'T SMOKE.**
- **EXTINGUISH ALL NAKED FLAMES.**
- **DON'T TURN ELECTRICAL SWITCHES ON OR OFF.**
- **TURN OFF THE GAS SUPPLY AT THE METER.**
- **OPEN DOORS AND WINDOWS TO GET RID OF THE GAS.**
- **IMMEDIATELY CALL THE GAS EMERGENCY SERVICE FROM A NEIGHBOURS PHONE - SEE YOUR LOCAL TELEPHONE DIRECTORY.**

Do have the fire installed by a competent person. In the United Kingdom, installation must be in accordance with the latest edition of the Gas Safety (installation & use) Regulations. In the Republic of Ireland, installation must be in accordance with all national and local regulations in force.

Do have the chimney swept prior to installation if it was previously used for solid fuel.
Do have the fire installed in accordance with the installation instructions.

Do allow a minimum clearance of 95mm from the top of the appliance fascia to the underside of any shelf whether it is made from combustible or non-combustible materials. This clearance is necessary to allow the fascia to be lifted off for servicing and also allows sufficient access to operate the control knob. For a shelf made from wood or other combustible materials deeper than 150mm add 12.5mm to the clearance for every 25mm of additional shelf depth (See figure 1). Please bear this in

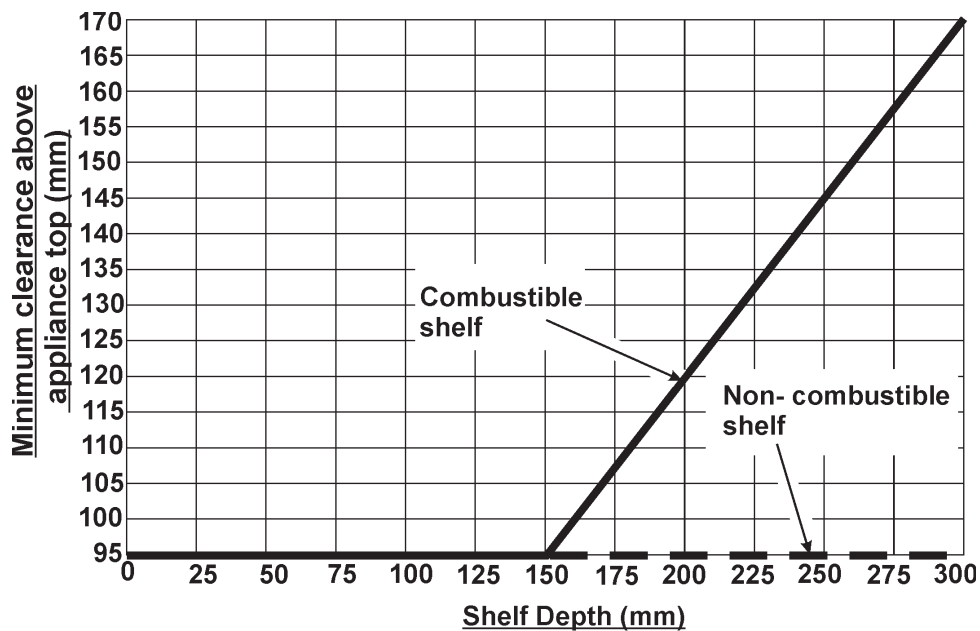

Figure 1. Shelf clearances

OWNER GUIDE

mind if ever you add a shelf.

Do get advice about the suitability of any wall covering near your fire. Soft wall coverings (e.g. embossed vinyl, etc.) which have a raised pattern are easily affected by heat. They may, therefore, scorch or become discoloured when close to a heating appliance. Please bear this in mind whenever you are considering redecorating.

Do provide a minimum clearance of 48mm between the fascia sides and any corner wall having combustible material or other combustible surface which projects beyond the front of the fire (See figure 2). Please bear this in mind if ever you are considering altering the room.

Do provide a suitable guard that complies with BS 8423 for the protection of young children, the elderly, the infirm and pet animals (Although this fire conforms to all the applicable standards, it is a heating appliance and certain parts of its surface will become hot).

Note: The guard supplied with the fire acts as a fireguard conforming to BS1945:1971 and satisfies the Heating Appliance (Fireguard) (Safety) Regulations 1991.

Do wait three minutes before attempting to relight if the fire is switched off or the flames are extinguished for any reason. (Your fire is fitted with a safety device that will automatically shut off the gas supply to the fire if, for any reason, the flames go out).

Don't hang clothing, towels or any other fabrics over the fire.

Don't fill in the space behind the fascia.

Don't use the fire without the dress guard being in position.

Don't attempt to clean or service the fire until it has been switched off and allowed to cool completely.

Don't use the fire with damaged radiants.

GAS CONSUMPTION

Has a maximum natural gas input of 5.5kW (Gross)

Has a maximum natural gas output of 4.0kW

Has a minimum natural gas input of 1.57kW (Gross)

Has a minimum natural gas output of 1.0kW

OWNER GUIDE

APPLIANCE DIMENSIONS

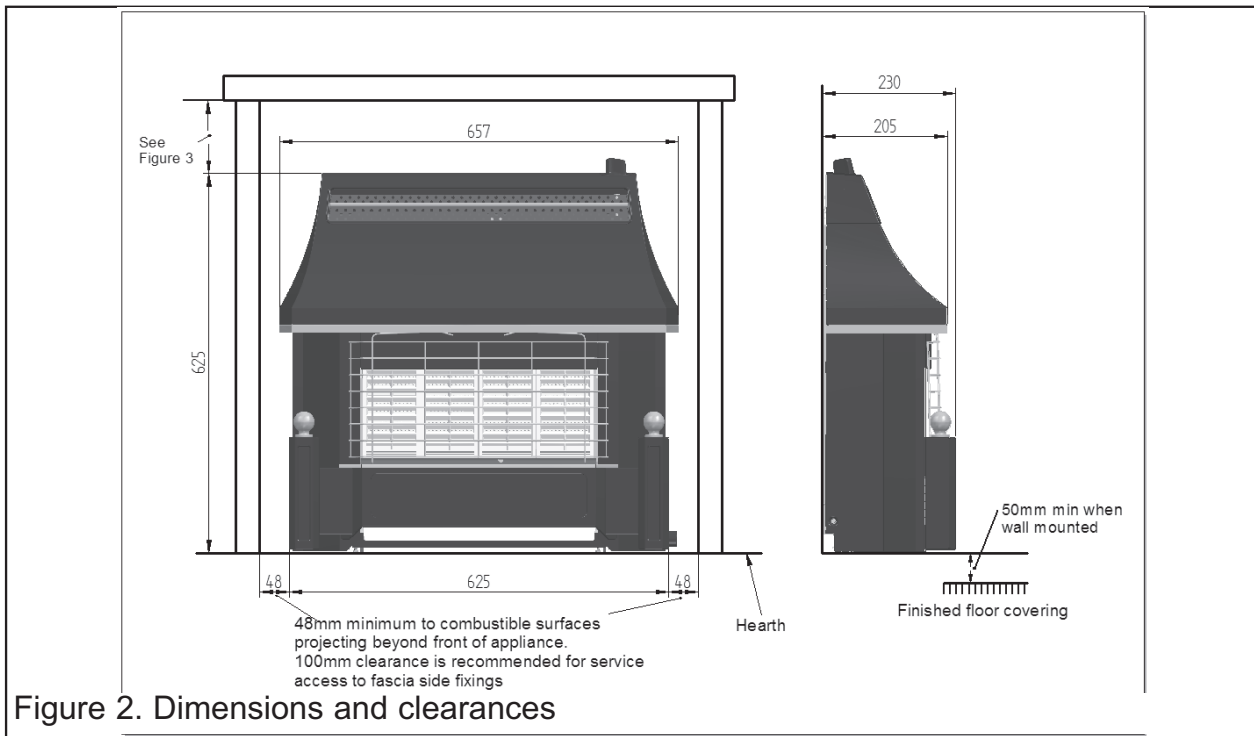

OPERATING YOUR FIRE

PLEASE NOTE

When operating your fire for the first time, some vapours may be given off which may cause a slight odour and could possibly set off any smoke alarms in the immediate vicinity. These vapours are quite normal with new appliances. They are totally harmless and will disappear after a few hours use.

The Oxysafe flame sensing and flue blockage safety system.

For your safety, this appliance is fitted with a flue blockage safety device that will shut down the appliance in the event of abnormal flue conditions. ***This device is NOT a substitute for an independently mounted Carbon Monoxide detector.***

The device will also automatically shut off the gas supply to the fire if the pilot flame goes out due to lack of oxygen or for any other reason.

If this device starts to repeatedly shut off the gas, get expert advice.

This device incorporates a probe that senses that the heat from the pilot flame is correct. If this probe is cool, the device will prevent any gas flow unless the control knob is held down at the ignition position.

If, for any reason, the flames go out when the fire is hot or if the fire is turned off when hot, always ***wait at least three minutes before attempting to relight.***

OWNER GUIDE

To light the fire (Electronic ignition-Helmsley).

The control is shown in figure 3.

– Depress the control knob slightly and turn anticlockwise towards the 1/IGN position. Do not apply too much pressure as this will cause resistance to be felt.

Depress the control knob. Sparks should be generated at the pilot. The sparks should ignite the pilot.

If the pilot does not light, turn the control knob back to the 'OFF' position and try again. The pilot flame can be seen through the opening immediately below the right hand centre radiant.

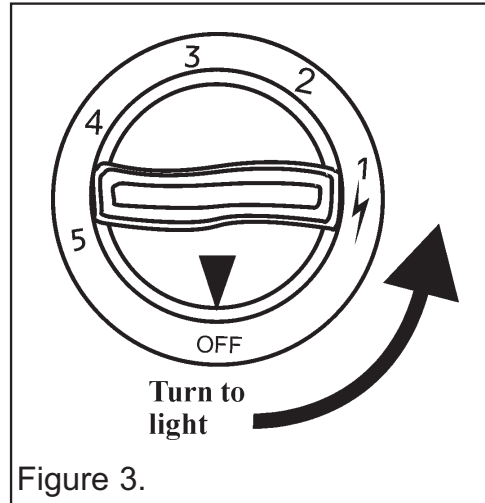

Figure 3.

If no sparks are generated at the pilot the battery may have no power. The battery can be replaced as shown later in this guide.

- When the pilot has lit keep the control knob depressed for about ten seconds to allow the flame sensing probe to warm up.
- The control knob can then be set to your preferred heat level.

To turn off partially depress the knob and turn clockwise to off. **Wait at least three minutes before attempting to relight.**

The control knob can then be set to your preferred heat level. The settings are:

Control Knob Position	Radiants Condition
2	Centre radiants on low. Outer radiants off. (The right hand centre radiant will glow slightly more than the left hand centre radiant due to the pilot flame)
3	Centre radiants fully on. Outer radiants off.
4	Centre radiants fully on. Outer radiants on low.
5	All radiants fully on.

OWNER GUIDE

CLEANING YOUR FIRE

Turn the fire off and allow it to cool before attempting any cleaning.

Normally the fire will only need dusting. The bright metal trims may be cleaned with a damp cloth and dried with a soft duster. Obstinate marks can be removed from the guard and trims using soapy water. **Never use abrasive cleaners.**

The radiants can be cleaned with a soft brush - see following section for how to remove the radiants.

REPLACING THE RADIANTS

(See figure 5). **Always use the correct type of replacement radiant. Ask for Valor Fires part number 5132071 (Single Radiant).**

Turn the fire off and allow it to cool before attempting to remove the radiants.

– Remove the dress guard by pressing down the two hooks at the top. Tilt the guard forward and lift out.

– Lift the radiant upward to clear the metal retaining bar then pull out bottom first.

– Fit the new radiant by inserting its top under the top lip of the radiant box then swing the bottom of the radiant over and behind the retaining bar. **It is important that that the rear face of the radiants rest against the horizontal ribs in the rear panel. There will be a small gap between their bottom front edges and the retaining channel at the front of the radiant box.**

– Replace the dress guard. Locate the bottom of the dress guard in the two holes in the bottom panel apron. Push the guard back so that the two spring projections at the top of the guard engage in the slots under the front decorative canopy.

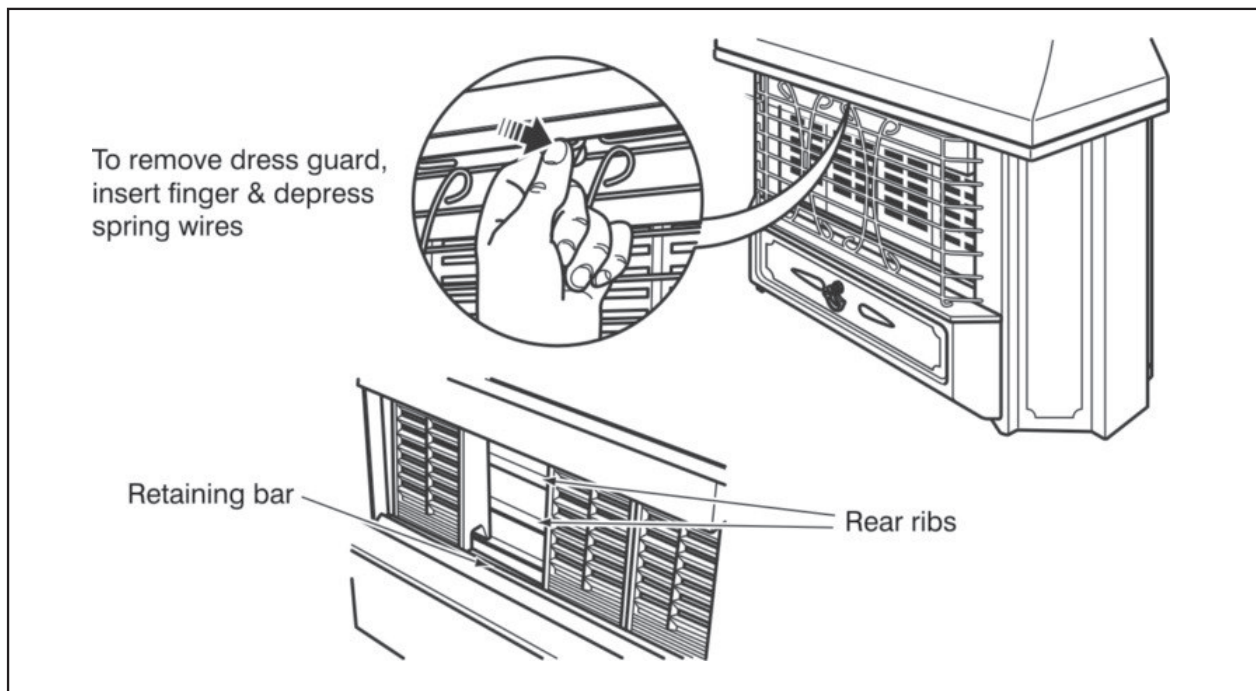

Figure 5. Replacing radiant(s) - grill shown may differ on Hemsley but same hooks

OWNER GUIDE

MAINTENANCE

Battery replacement (Electronic ignition).

1. The battery cover is located at the base of the fire on the right hand side.
2. Unscrew the battery cover in an anticlockwise direction.
3. Remove the battery and discard.
4. Remove any protective film from the replacement battery and place into the generator. The negative (-) terminal should go in first. The cap of the generator is marked with (+).
5. Refit the battery cover.

Regular maintenance.

In order to achieve and maintain high levels of personal safety and performance efficiency, it is essential that the opening at the back of the fire and the flue are kept clear of any form of obstruction. It is possible that deposits of mortar or soot could fall and accumulate causing the flue to be blocked or restricted and so preventing proper clearance of dangerous exhaust fumes.

In the United Kingdom it is the law that a landlord must have any gas appliance, flue and pipework which is situated in a tenant's premises checked for safety at least every twelve months by a competent person (In the UK a GAS SAFE REGISTER engineer, outside of the UK a CORGI or GAS SAFE REGISTER engineer). We recommend that all gas appliances and their flues, wherever situated, are checked annually.

OWNER GUIDE

WARRANTY AND SERVICE

Standard Warranty Terms & Conditions

The warranty is for 12 months subject to contract.

In the United Kingdom servicing can be carried out either by a **GDC** service engineer or a **GAS SAFE REGISTER** engineer. Outside of the United Kingdom servicing can be carried out either by a **CORGI** or **GAS SAFE REGISTER** engineer. You must register your fire with by calling our telephone registration line on **08444 810 214**.

It is also a requirement of the warranty that the fire has an annual service (every 12 months) in accordance with the installation and servicing instructions, performed by a GAS SAFE REGISTER engineer, (CORGI or GAS SAFE REGISTER outside of UK)

Our promise to you

If you experience a fault with your new fire, we aim to provide a safe and high quality repair service supported by our dedicated national network of highly skilled engineers. If your installer can't resolve the problem for you, we will do everything we can to get an engineer out to you as quickly as possible. Nothing in this warranty will affect your statutory rights.



Benchmark Checklist/Service Record

Please ensure that the installer has fully completed the Benchmark Checklist on the inside back pages of the installation instructions supplied with the product and that you have signed it to say that you have received a full and clear explanation of its operation. The installer is legally required to complete a commissioning checklist as a means of complying with the appropriate Building Regulations (England and Wales).

Installations carried out in England and Wales must be notified to Local Area Building Control either directly or through a Competent Persons Scheme. A Building Regulations Compliance Certificate will then be issued to the customer who should, on receipt, write the Notification Number on the Benchmark Checklist.

The filled in Benchmark Checklist/Service Record by the installer will be required in the event of any warranty (UK and Ireland installation).

After servicing, complete the relevant "Service Interval Record" section of the Benchmark Checklist located on the inside back pages of this document.

OWNER GUIDE

What you need to do if you experience a problem with the operation of the fire:

- You should always contact your installer first, because the cause of the fault may not be related to the fire.
- If your installer confirms that the fault is with the fire and they can't repair it, our friendly customer service team is on hand to help.
- Simply call our UK GDC Helpline on **0844 879 35 88** or from the Republic of Ireland call **01 842 8222** for any general advice that you may need.

When calling the **GDC Helpline**, it would be helpful if you could have the following information to hand:-

1. Fire serial number and fascia code (The serial number can be found on the serial number label - See figure 6.*
2. Date of installation*
3. Your installer name and address details*
4. Fire make and model number*
5. Annual Service record details*
6. Proof of purchase (if you do not have the fire serial number)

***Note: details 1 – 5 should be recorded as part of the Benchmark Checklist / Service record at the end of this guide.**

What this warranty covers

Free of charge repair or replacement of components found to be of faulty manufacture.

Free of charge replacement of the complete unit providing the failure is related to a manufacturing fault that cannot be repaired or is uneconomic to repair.

What this warranty does not cover

Repairs to fires which haven't been installed and commissioned properly and as set out in the installation instructions.

Faults caused by inadequate supply of gas or electricity (where applicable).

Reimbursement of any third party repair or replacement costs that we haven't been told about or agreed with you in advance.

Compensation or consequential losses (e.g. loss of earnings, business losses, stress and inconvenience) arising from a production breakdown, including repair delays caused by factors outside our reasonable control.

OWNER GUIDE

GAS FIRE COMMISSIONING CHECKLIST

This Commissioning Checklist is to be completed in full by the competent person who commissioned the gas fire as a means of demonstrating compliance with the appropriate Building Regulations and then handed to the customer to keep for future reference.

Failure to install and commission according to the manufacturer's instructions and complete this Benchmark Commissioning Checklist will invalidate the warranty. This does not affect the customer's statutory rights.

Customer name:	Telephone number:	
Address:		
Gas Fire make and model:		
Gas Fire serial number:		
Commissioned by (PRINT NAME):	Gas Safe register number:	
Company name:	Telephone number:	
Company address:		
		Commissioning date:
Building Regulations Notification Number (if applicable):		
Site Requirements	Yes	N/A
Was the chimney checked to ensure it only serves one flue/fire, has no obstructions and is continuous?		
Has any debris at the base of the chimney been removed?		
For brick chimney installations is there enough depth for 12 litres of debris, or precast flues 2 litres of debris? (see instructions for debris gap details)		
Have damper and register plates been removed or locked in the fully open position ensuring correct size of flue is maintained?		
If previously used for solid fuel has the chimney been thoroughly swept?		
If the chimney is pre-cast has the inside of the flue been checked for extruded cement / sealant which must be removed?		
Has the fire place been checked for under-floor air supply which must be sealed off?		
Has the chimney been inspected prior to fitting the gas fire to ensure that it is in good condition?		
Has the structure of the chimney been checked for leakage using a smoke pellet test? (See BS5440-1 for details).		
Ventilation		
Does the installation require any additional ventilation requirements as detailed in the manufacturer's instructions?		
Hearth Requirements- where fitted		
Is the hearth constructed from non-combustible material?		
Is the hearth a minimum of 12mm thick with a minimum floor to top surface of 50mm?(BS5871) or as per manufacturer's instructions?		
Is the hearth for open fronted fires a minimum of 760mm wide and has 300mm projecting from the fire opening (BS6871) or to manufacturer's instructions?		
Mounting height (where applicable) has the fire been installed to the correct mounting height- as per manufacturer's instructions?		
Firebox and Fuel Bed		
Has the fuel bed, coals, pebbles etc. been fitted to manufacturer's instructions?		
Gas Supply		
Has an isolation tap/restrictor inlet elbow been fitted for servicing?		
Has the gas supply been thoroughly purged prior to connection to remove any debris?		
Has a gas tightness test been completed prior to breaking into the gas supply and following completion of installation?(IGEM/UP/1B)		
Record burner gas pressure reading? If only the supply pressure is available a gas rate must be undertaken.(GSIUR REG26/9C)		
Record dynamic inlet gas pressure (working pressure) reading (all gas appliances running)		
Spillage test		
Installation passes smoke match test with any extractor fans turned on (see manufacturer's instructions)		
Installation		
Has the gas fire been installed and commissioned in accordance with manufacturer's instructions?		
Has the fire been installed with the correct clearance to combustible materials, as per manufacturer's instructions?		
The operation of the appliance and controls have been demonstrated to the customer including battery replacement where applicable?		
The manufacturer's literature, including Benchmark Checklist and Service record has been explained and left with the customer?		
Has the appliance been registered with the Local Authority as detailed on the Gas Safe web site and is a legal requirement and forms part of the warranty?		
Customer's Signature: (To confirm satisfactory demonstration and receipt of manufacturer's literature)	Commissioning Engineer's Signature:	

*All installations in England and Wales must be notified to be Local Authority Building Control (LABC) either directly or through a Persons Scheme. A Building Regulations Compliance Certificate will then be issued to the customer.



© Heating and Hot Water Industry Council (HHIC)

www.centralheating.co.uk

OWNER GUIDE

SERVICE RECORD

It is essential that your gas fire is serviced regularly and that the appropriate Service Interval Record is completed.

Service Provider

Before completing the appropriate Service Record below, please ensure you have carried out the service as described in the manufacturer's instructions. Always use the manufacturer's specified spare part when replacing controls.

SERVICE 01	Date:	SERVICE 02	Date:
Engineer name:		Engineer name:	
Company name:		Company name:	
Telephone No:		Telephone No:	
Gas safe register No:		Gas safe register No:	
Comments:		Comments:	
Signature		Signature	
SERVICE 03	Date:	SERVICE 04	Date:
Engineer name:		Engineer name:	
Company name:		Company name:	
Telephone No:		Telephone No:	
Gas safe register No:		Gas safe register No:	
Comments:		Comments:	
Signature		Signature	
SERVICE 05	Date:	SERVICE 06	Date:
Engineer name:		Engineer name:	
Company name:		Company name:	
Telephone No:		Telephone No:	
Gas safe register No:		Gas safe register No:	
Comments:		Comments:	
Signature		Signature	
SERVICE 07	Date:	SERVICE 08	Date:
Engineer name:		Engineer name:	
Company name:		Company name:	
Telephone No:		Telephone No:	
Gas safe register No:		Gas safe register No:	
Comments:		Comments:	
Signature		Signature	
SERVICE 09	Date:	SERVICE 10	Date:
Engineer name:		Engineer name:	
Company name:		Company name:	
Telephone No:		Telephone No:	
Gas safe register No:		Gas safe register No:	
Comments:		Comments:	
Signature		Signature	



OWNER GUIDE

To be completed by installer:

Installer Details (Block Capitals)

Installer Name	
Gas Safe Register or Corgi Registration Number.	
Company Name.	
Company Address	
Company Telephone number	
Company Fax number	

OWNER GUIDE

Model

Serial number (Can be found on the serial number label - See figure 6)

A LABEL CONTAINING THE SERIAL NUMBER MAY HAVE BEEN PLACED INSIDE THE BOX.

Fascia name (Block Capitals)

Fascia code - Can be found close to the information label (Block Capitals)

A LABEL CONTAINING THE FASCIA CODE MAY HAVE BEEN PLACED INSIDE THE BOX.

Brand (Please tick)

Valor

Other.....

Date of Installation

D D M M Y Y

